

Lx POL Research Microscopy

User Manual

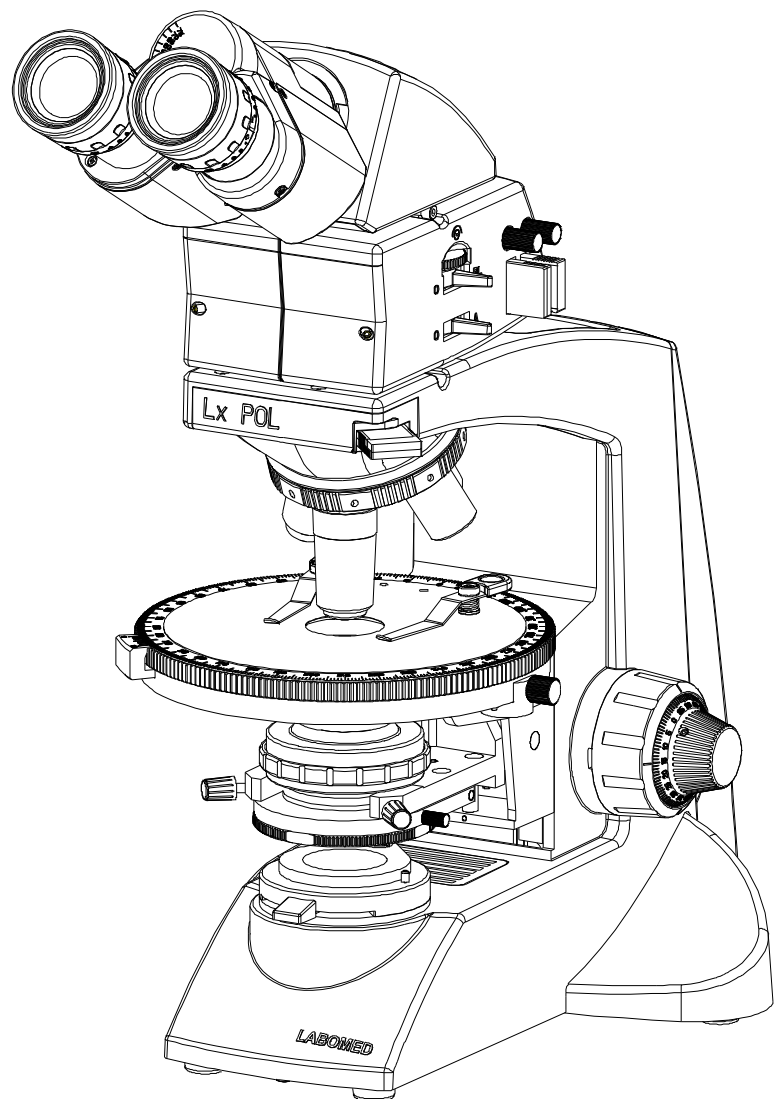

To ensure proper use of this instrument as well as to avoid injury while operating Instrument, understanding this manual completely before use is highly recommended.

Part No: 9151000-795
Issue 1.4
Printed on July,2021

TABLE OF CONTENTS

1. INTRODUCTION	1
2. SAFETY INFORMATION	2-4
a. General Instructions	
b. Safety Symbols	
c. Maintenance & Care	
d. Health Risks	
3. GENERAL USE INSTRUCTIONS	5
4. REPLACEMENT OF PARTS	6-7
5. Lx POL BINOCULAR	8
6. Lx POL TRINOCULAR	9
7. UNPACKING YOUR MICROSCOPE	10
8. STANDARD COMPONENTS	11
9. OPTIONAL ACCESSORIES	12
10. INSTALLATION AND OPERATION OF OPTIONAL ACCESSORIES	13
a. Camera Module System	
b. Optional Eyepieces	
11. DETAILED INTRODUCTION OF ASSEMBLIES	14-16
a. Abbe Condenser	
b. Polarizer	
c. Round Stage	
d. Centerable revolving nose piece	
e. Objectives	
f. Eye pieces	
g. Bertrand Lens	
12. INITIAL SETUP	17-18
a. Observation Head	
b. Eye Pieces	
c. Mounting the Day Light (Blue) Filter	
d. Stage Clips	
e. Connecting Power Cords	
13. CENTRATION	19-21
a. Preparation for centration	
b. Kohler illumination centration	
c. Abbe Condenser centration	
d. Objective centration	
e. Extinction adjustment	
f. Conoscopic adjustment	

14. SUMMARY OF POLARISED OBSERVATION PROCEDURE	22
15. DETAILED OBSERVATION PROCEDURE	23-26
a. Placing the specimen on stage	
b. Adjusting the focus	
c. Adjusting the Interpupillary Distance	
d. Adjusting the Diopter	
e. Adjusting the Condenser position and Aperture Iris Diaphragm	
f. Switching the objectives	
g. Using the 100x Immersion Objective	
16. TROUBLESHOOTING GUIDE	27-28
17. SPECIFICATIONS	29

The Lx POL is a research polarizing microscope reflecting a modern design as well as the latest in optical and mechanical advancements. Designed for professionals, this microscope offers many features and functions for a diverse set of applications. It is a truly professional polarizing Microscope that meets, and indeed exceeds the quality of some of the competing Microscopes. Here are a few points highlights the benefits of the Lx POL:

- Extra clarity and contrast is provided through a 360 degree rotatable viewing body inclined at 30 degree with IPD adjustments.
- The pressure die cast stand consists of ball bearing, frictionless sideways focusing to avoid any loss motion.
- The sturdy new stylish design provides a high degree of comfort as well as stability.
- The high powered objectives are spring loaded to prevent accidental damage to specimen slides.
- The highly precision Parfocalized & Parcentered reverse angle quadruple nose piece has the provision of centering for all objectives.
- The round ball bearing Rotatable Stage has smooth 360degree travel and has 1 degree graduations on the scale which provides accurate location of the specimen.
- High power illumination is delivered through our well crafted Universal Power Supply and operates with any 100V-240V AC input. The LED configuration is operational with an in-built rechargeable battery P/N 9135000-902, Which when plugged in, draws power from a Universal Power Supply operating at 100V-240 AC input. This ensures continuous operation even under fluctuation voltages.
- Our Halogen bulb (6V-20W) has an average life span of upto 2,000 hours. Our LED has an average life span of upto 60,000 hours.
- The Lx POL is equipped with a Abbe Condenser N.A. 1.25 to attain for brighter illumination levels. An iris diaphragm is also provided for better resolution and contrast control.
- High quality Polarize & Analyzer filters for perfect extinction level.
- Polarizer: This is provided below the condenser and is 360 degree graduated and lockable in any desired position.
- Analyzer: The advances Analyzer module is located below the viewing tube and provides specific cross polarization through the full 90 degree quadrant.
- A center adjustable focusable Bertrand lens is a standard feature in the module which provides conoscopic observation.
- A set of high quality compensator for advanced polarized observation include Gypsum full wave length Quartz Wedge and A Mica 1/4 wave plate.



2 SAFETY INFORMATION

a GENERAL INSTRUCTIONS

1. A microscope is a precision instrument with delicate glass components, please handle with care.
 2. Do not use the microscope where it is subjected to direct sunlight, high temperature, humidity, dust and vibrations.
 3. The microscope is ventilated by natural convention. Be sure to leave enough space (10 cm or more) around body when installing the unit.
 4. Arm handle is provided for carrying the microscope.
- To prevent damage, do not hold the microscope by the stage or observation tube. Be sure to remove the specimen from the stage clip while transporting unit to avoid damage to the specimen slide.

b SAFETY SYMBOLS

The following symbols are found on the microscope. For optimal use, it is recommended that users understand these symbols and always use the equipment as prescribed:

Symbols	Explanation
	The surface has a tendency to heat up and should not be touched unless system has completely cooled down.
	Before use, carefully read the instruction manual. Improper use could result in injury to the user and/or damage to the equipment.
	Warning against risk of electric shock.
	Main switch is ON.
○	Main switch is OFF.

If the microscope is used in a manner not specified by this manual, the safety of the user may not be warranted. In addition, the equipment may also suffer damage. Always use the equipment as outlined in this instruction manual.

c MAINTENANCE AND CARE

1) GENERAL CLEANING

Your Microscope has been engineered for a long and safe operational life with the least amount of maintenance required. In general, routine maintenance is limited to keeping the microscope working parts lubricated and optics clean.

- Clean all glass components by wiping gently with cleaning cloth provided. To remove fingerprints or oil smudges, wipe with cleaning cloth slightly moistened with a mixture of petroleum (85%) and isopropanol (15%).

 **Since solvents such as petroleum and isopropanol are highly flammable, they must be handled carefully. Be sure to keep these chemicals away from open flames or potential sources of electrical sparks- for example, electrical equipment that is being switched “ON” or “OFF”. Also remember to always use these chemicals only in a well-ventilated room.**

1. Do not attempt to use organic solvents to clean the microscope components other than the glass components. To clean non-glass components, use a lint-free, soft cloth slightly moistened with a diluted neutral detergent.

2. Do not disassemble any part of the microscope as this could result in malfunction or mitigated performance.
3. When not using the microscope, ensure that the frame is fully cooled before storing the unit in a dry locker or covering with dust cover (provided).
4. To clean the Condenser, fully loosen the securing thumb screw(1) and remove the condenser then, wipe the front lens of the condenser with optical cleaning solution(mixture suggested above) and lens tissue. The condenser Abbe can be re-attached in its seat, by tightening securing thumb screw, and raising condenser brackets to desired position. (as shown in picture)
5. Always cover the microscope with the provided dust cover when not in use

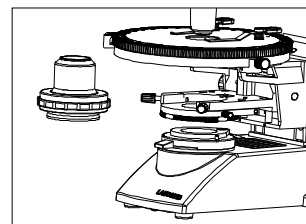

II) OPTICAL CLEANING

1. The objective have been adjusted for a tight fit to prevent any damage during transportation. To remove an objective, rotate it counterclockwise while gripping it with a rubber sheet, etc. to avoid any slippage.
2. To clean the lens surfaces, remove dust using a soft brush or gauze (compressed air dust cans are ideal). For removing finger marks or grease, soft cotton cloth or lens tissue lightly moistened with cleaning solution (85% petroleum ether and 15% isopeopanol) should be used. For cleaning the optics, use Meathanol. Observe sufficient caution in handling Methanol. Place the Objective eyepieces on a dust free surfaces (e.g. aluminum foil). All other optical components to be cleaned should be as accessible as possible.
3. Blow all loose dust particles away with a dust blower.
4. Remove all water-soluble dirt with distilled water. If this is unsuccessful repeat using a solution of diluted hand soap liquid. Remove any remaining residue with a dry cotton swab.
5. To remove oil, use a solution of diluted hand-soap liquid initially. If this does not produce a satisfactory result, repeat the cleaning using a solvent (Optical Cleaning Solution 85% petroleum ether and 15% isopropanol).
6. Grease must always be removed using a solvent.
7. Cleaning is achieved by using a spiral motion from the center to the rim. Never wipe using zig-zag movements as this will only spread the dirt. With larger optical surfaces (e.g. tube lenses) the spiral motion starts initially at the rim before to the middle and is only then followed by a center to rim cleaning motion. Normally several spiral wipes are recommended.

We recommend pure, volatilepetroleum ether or Optical Cleaning Solution as explained in point 3 above.

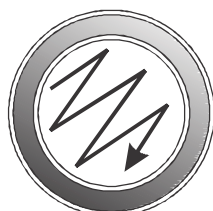

Wipe using a spiral movement

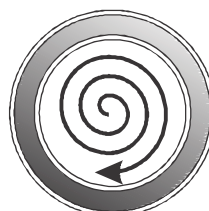

Do not use a zig-zag motion

III) Cleaning of Painted Surfaces

Avoid the use of any organic solvent (e.g. thinner, xylene, ether, alcohol etc.) for cleaning of painted surfaces of the instrument. Painted surfaces can be cleaned with a very lightly moistened micro fiber cloth. Loose dust and other dirt particles can be removed using a soft bristle brush used exclusively for this purpose.

d HEALTH RISKS

This microscope has an ergonomic design that ensures minimum exertion of the user. However, some of the risks that the user should keep in mind are:

I) RISK OF INFECTION:

After the microscope has been used for observation of a specimen containing bacteria, clean all parts coming in contact with the specimen to prevent infection.

1. Be sure to remove the specimen before moving this product.
2. In case the specimen is damaged by erroneous operation, it is important to clean all surfaces that may come in contact with the specimen.

II) ELECTRICAL HAZARDS:

2. To avoid potential electrical hazards when replacing either halogen bulb or LED, turn the microscope main switch to the OFF position and disconnect power cord from wall outlet in advance. Whenever you replace your microscope bulb, allow lamp socket and bulb to cool before touching (Fig.1)

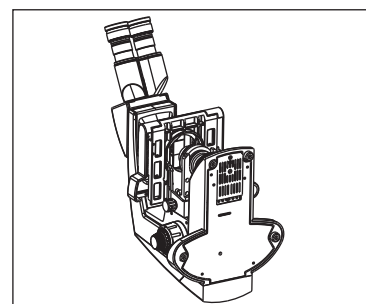

Fig. 1

Applicable bulb/LED replacement: 6V20W Halogen bulb P/N CX-013; 6V30W Halogen bulb P/N EL-455 or LED P/N 9135000-901

E

3 GENERAL USE INSTRUCTIONS

1. Install microscope on a sturdy, level table or bench and avoid any restriction of air vents in the base of the unit. Do not place microscope on a flexible surface as this could result in blocking the air vents and cause overheating.
2. Always use the power cord provided by LABOMED. If the proper power cord is not used, product safety performance cannot be warranted.
3. When installing the Microscope, route the power cord away from the microscope frame, Should the power cord come in contact with the Microscope base, the power cord could melt due to overexposure heat.
4. Always ensure that the grounding terminal of the Microscope and that of the wall outlet are properly connected. If the unit is not grounded. LABOMED can not warrant electrical safety.
5. Never allow metallic objects to penetrate the air vents of the Microscope frame as this could result in user injury and damage to the Microscope.
6. After operation of Microscope, be sure to disconnect power cord from connector socket of the Microscope or from the wall power outlet.

E

I) INSTALLING OR REPLACING THE LAMP BULB

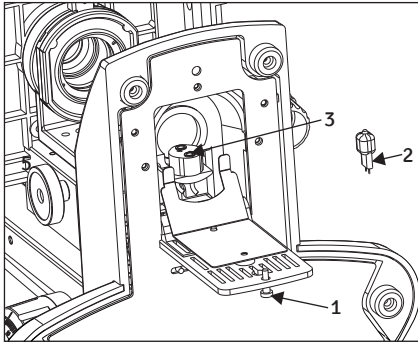

Fig. 2

Before attaching the lamp bulb, remove the parts that may drop such as the filter and specimen from the microscope frame, and place the microscope in its back so that the bottom plate is exposed.

1. Pull the lock knob (1) on the bottom to open lamp housing door (fig.2).
2. Hold the halogen bulb (2) without taking it out of the polyethylene bag so as not to taint the bulb with fingerprints and push the bulb into the pin holes on the socket (3). After attaching, remove the polyethylene bag.
3. With the lock knob pulled out, close the lamp housing door, then push the lock knob back to lock the cover.

Always use the designated bulb. Using a bulb other than those specified by LABOMED may lead to a fire hazard or low illumination. Fingerprints or stains on the lamp bulb reduce its life. If contamination occurs, wipe bulb surface with a cloth slightly moistened with alcohol.

Applicable Bulb: 6V20W Halogen Bulb P/N CX-013

CAUTION: For Bulb Replacement During Use or Right After Use

The bulb, lamp socket and areas near these will extremely hot during and right after use. Set the main switch to "O" (OFF), disconnect the power cord from the wall outlet, and allow the bulb and lamp socket to cool before replacing the bulb with a new bulb of the designated type. Cooling time may vary to users Discretion.

II) PROCEDURE FOR LED REPLACEMENT

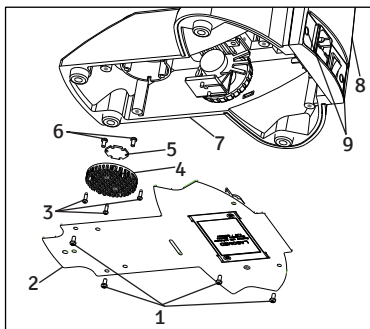

Fig. 3

1. Screws SS 658
2. Base Plate 9126100-301
3. Screws Heat Shield SS 714
4. Heat Shield 9135000-524
5. Star LED 9135000-901
6. LED Screws SS 658
7. Stand
8. Back Cover Plate 9126000-102
9. Electric Panel 9126000-103
10. Decorative Cap 8123000-202

Figure 3

1. Pull out two decorative caps (shown as 9) from back cover plate.
2. Using Cross head screw driver, unscrew two screws (shown as 9) to detach back cover plate from stand.
3. Lay down the microscope on back cover over a clean surface to expose base plate.
4. Using Cross head screw driver, unscrew four screws (shown as 1) to open the bottom plate of the microscope.
5. Cut LED wire holding tie and Detach LED wire connector from PCM mounted on back cover plate.
6. Detach Heat Shield from critical mount by opening 3 screws (shown as 3) with cross head screw driver.
7. Detach LED from Heat Shield by loosening 2 screws (shown as 6).
8. Replace new LED on Heat Shield and connect wire connections

Applicable LED replacement: LED P/N 9135000-901

(III) PROCEDURE FOR BATTERY REPLACEMENT

Fig. 4

1. Screws for Battery cover bottom SS 658
2. Battery cover 9135100-204
3. Battery 9135000-903
4. Cable clamp EL-488
5. Battery clamp X54383
6. Screws Battery clamp SS 658

Figure 4

1. Lay down the microscope on back cover on a clean surface to expose base plate.
2. Using Cross head screw driver, unscrew four screws (shown as 1) to open the battery cover from bottom plate.
3. Detach connector of connecting wires (shown as 4)
4. Remove two screws (shown as 6) provided on battery clamp with Cross head screw driver.
5. Replace existing Battery with new battery from LABOMED (Refer part no. below)
6. Reverse steps 5 to 1, to complete the process.

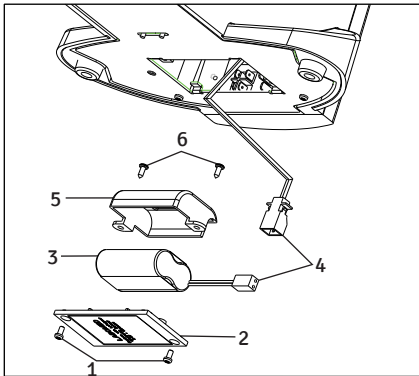
Applicable LED Battery Replacement: LED P/N 9135000-903

5 Lx POL BINOCULAR

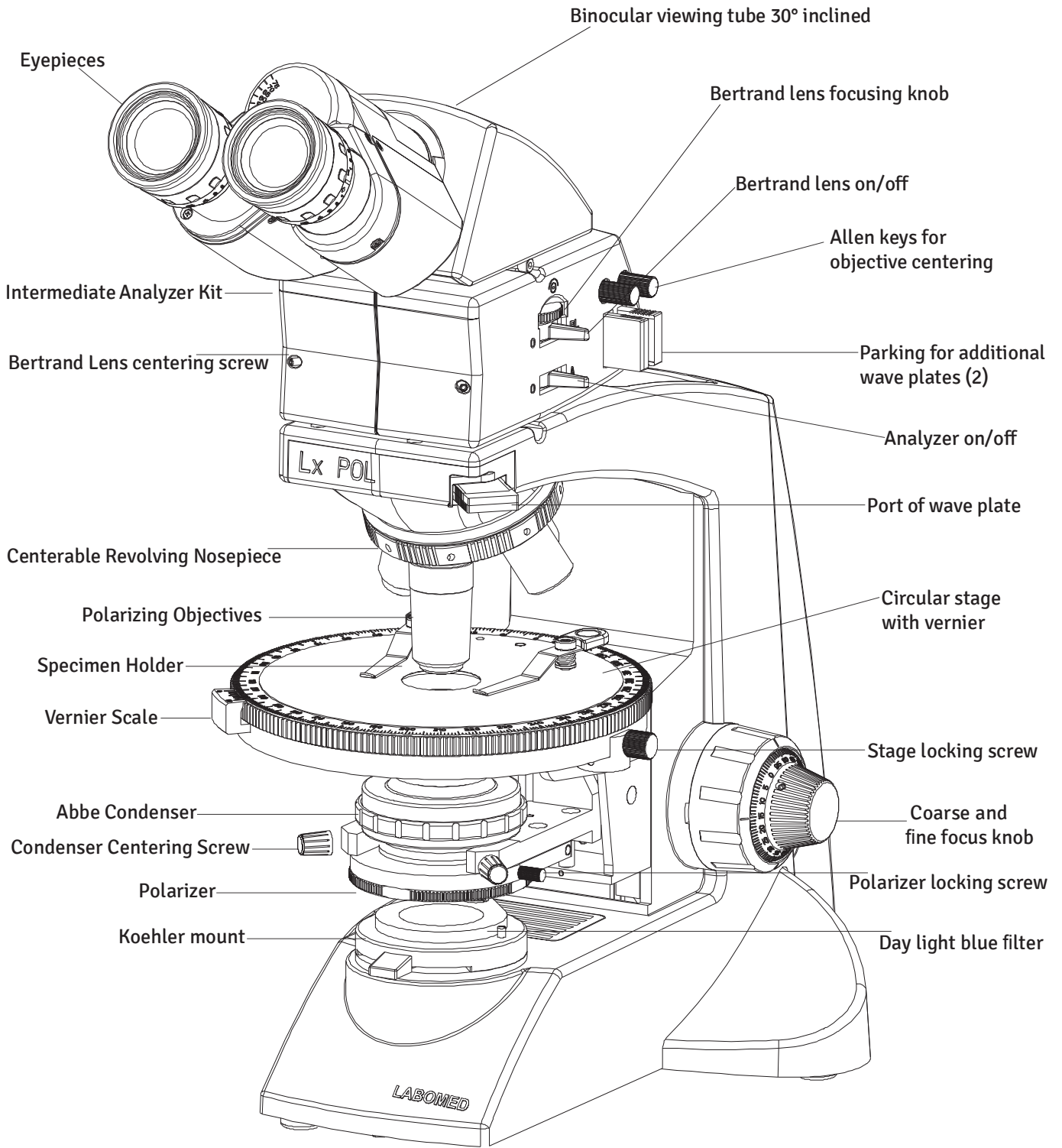

6 Lx POL TRINOCULAR

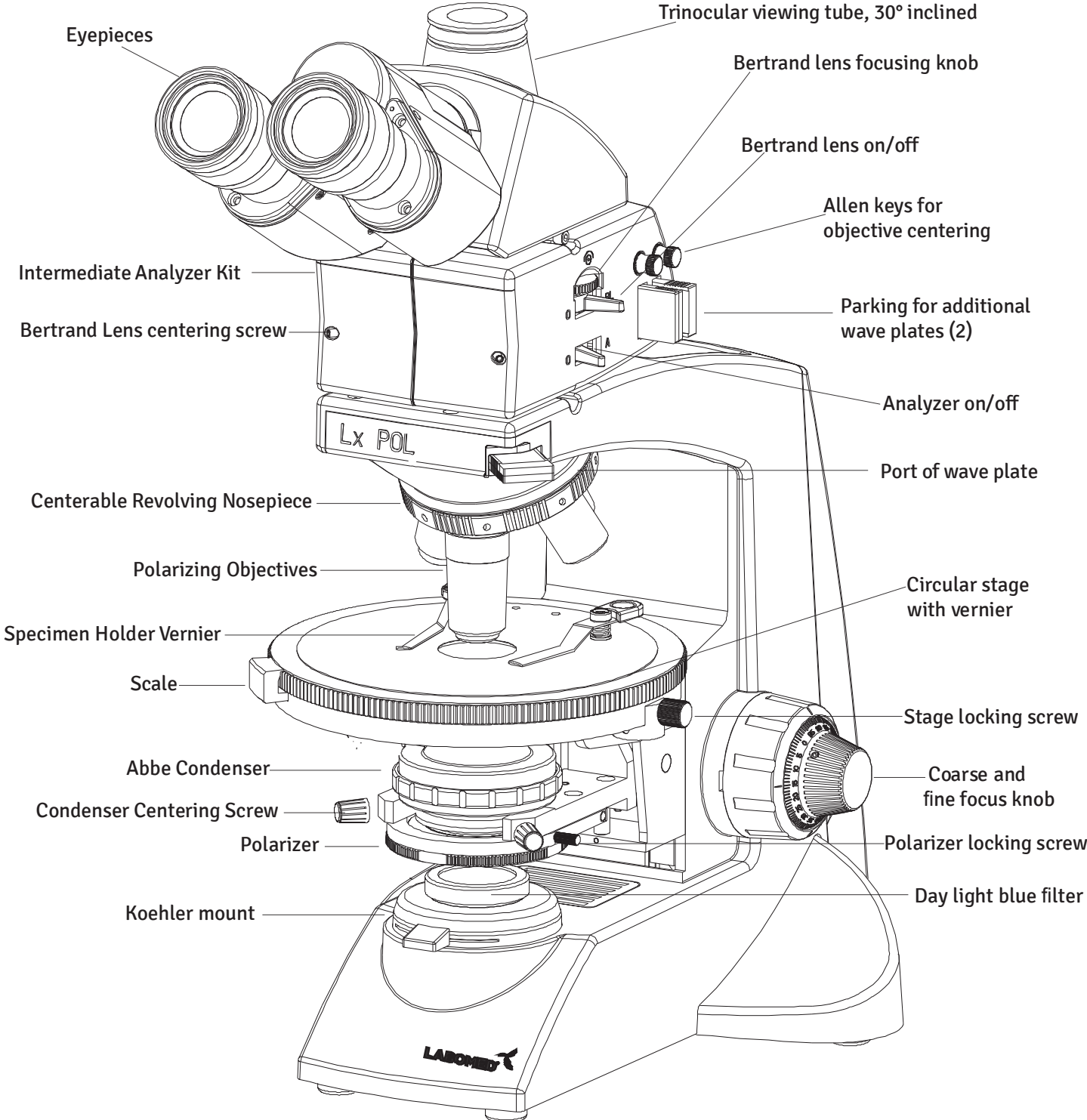

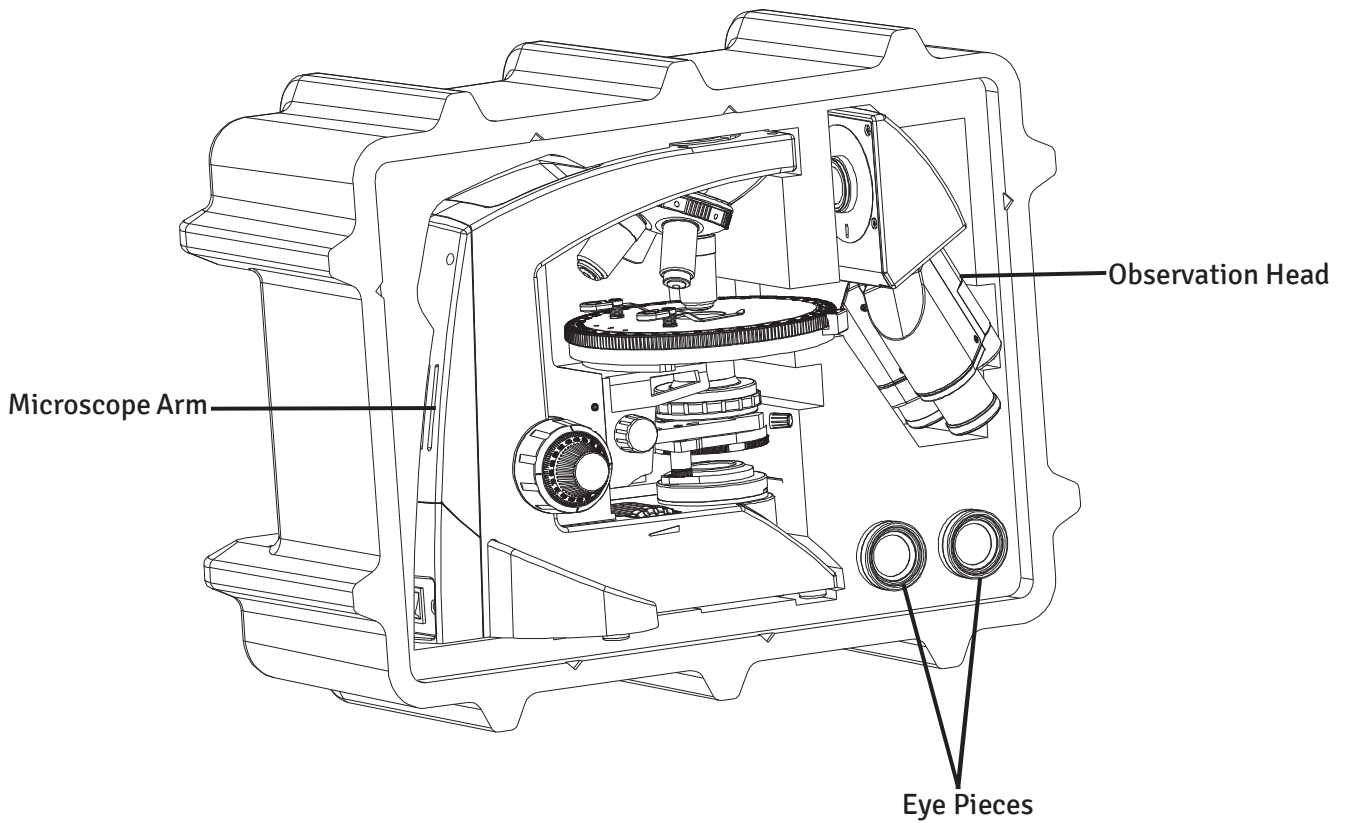
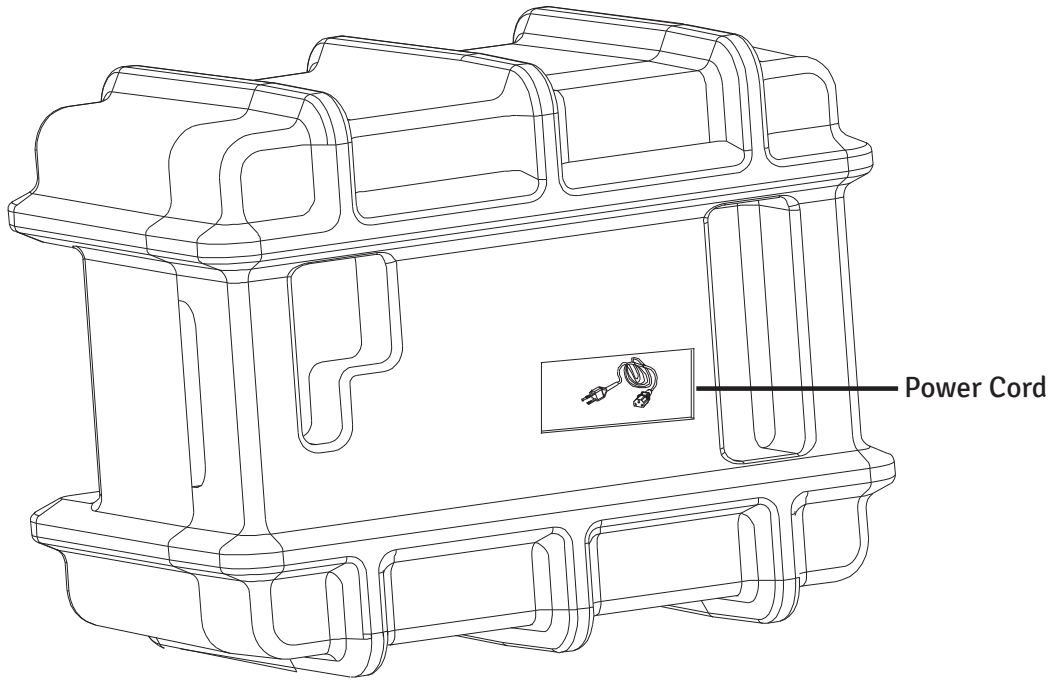

8 STANDARD COMPONENTS

After removing your microscope from its packaging, make sure that all of the following contents are present. “Please note that the contents of your microscope may vary as the optional configuration, contrasting method or viewing body opted for may not be of the standard configuration highlighted here”.

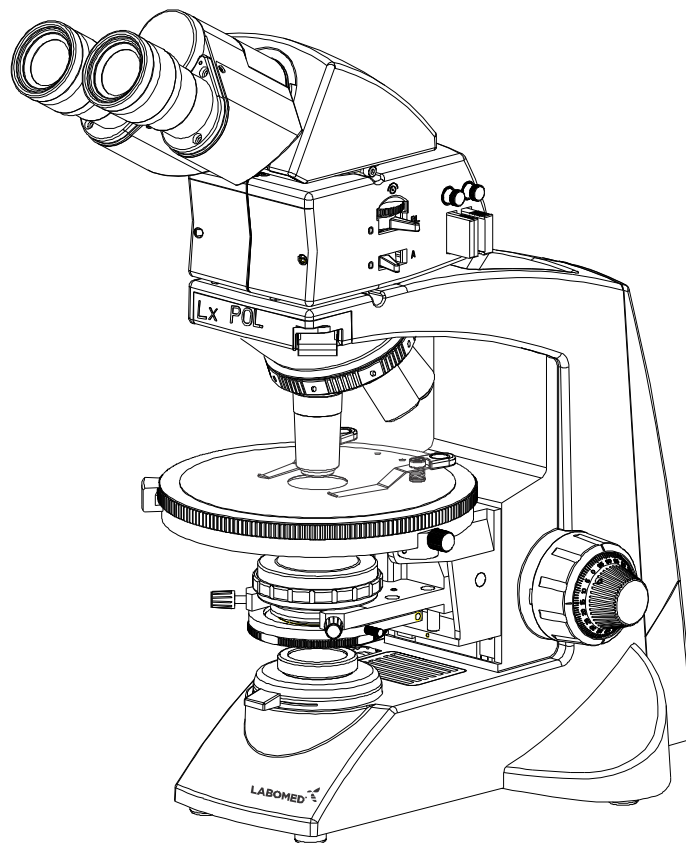

Daylight (blue) filter



Paired Eyepieces



Allen Wrench 3mm

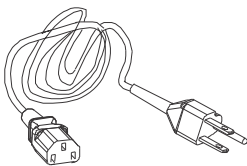

Power Cord



6V 20W Halogen bulb

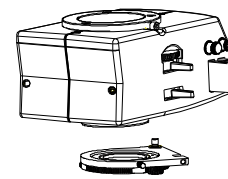

Polarizing attachment

SYSTEM DIAGRAM OF OPTIONAL ACCESSORIES

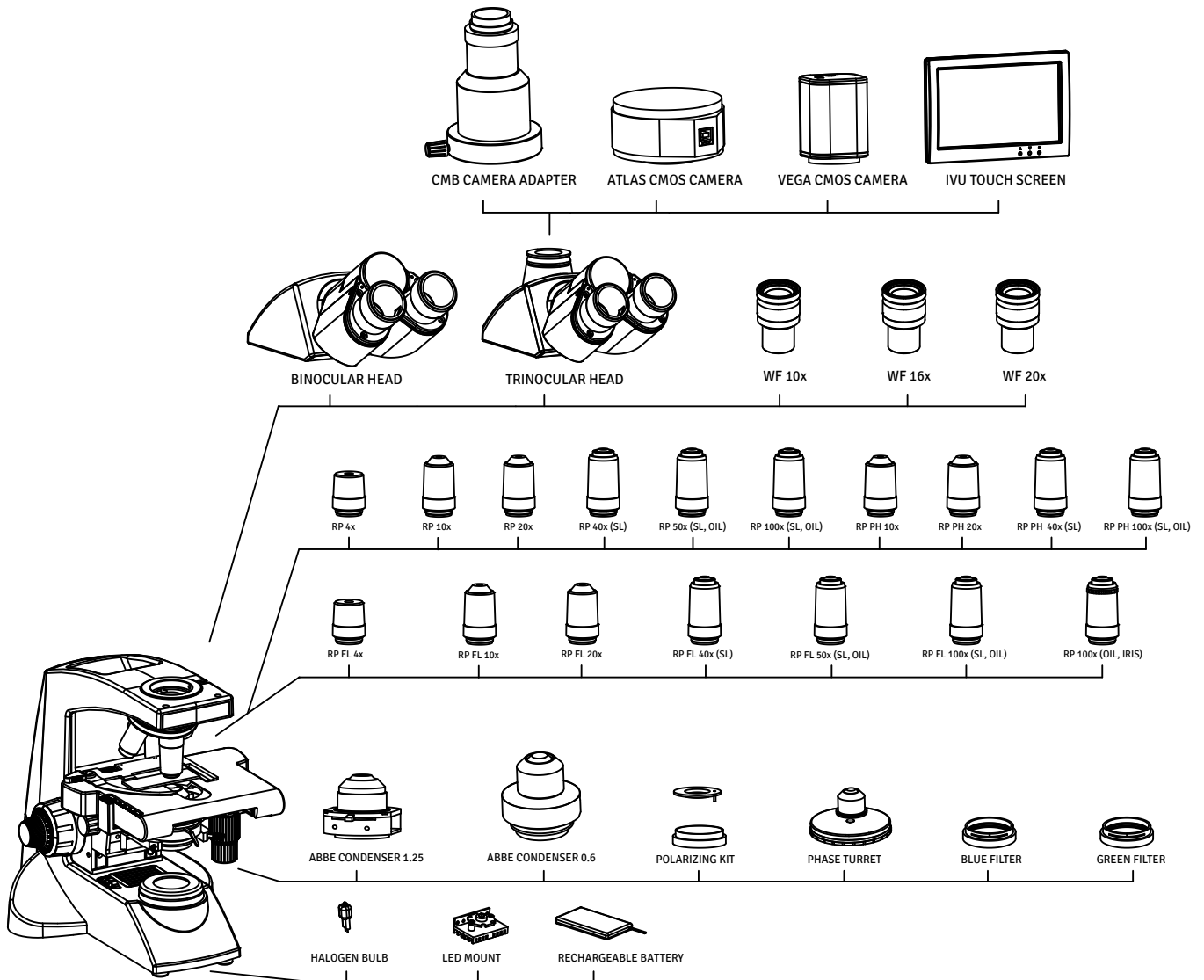

a CAMERA MODULE SYSTEM

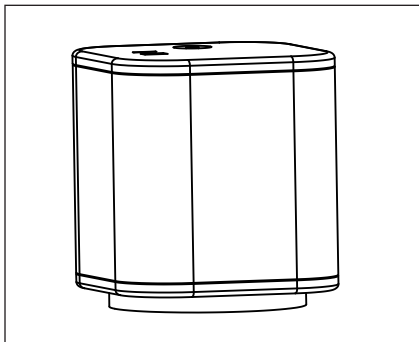

Fig. 5

1. Mount the Video adapter 1/2" on Trinocular observation head.
2. Mount Camera Module System on Video adapter.

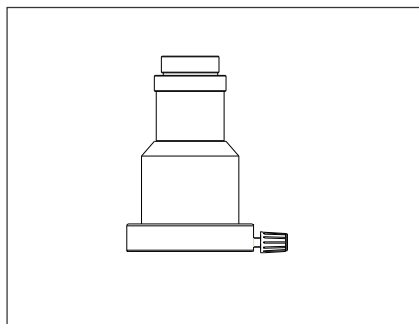

Fig. 6

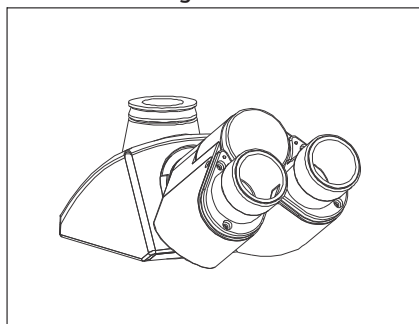

Fig. 7

b OPTIONAL EYEPIECES

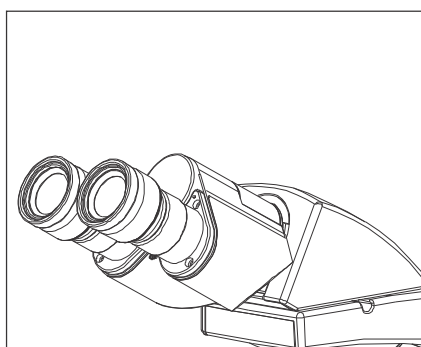

Fig. 8

10X eyepieces are provided. To replace:

1. Pull out the 10x eyepieces out from the observation heads ocular tube.
2. Insert desired eyepieces in empty ocular tube.

a ABBE CONDENSER

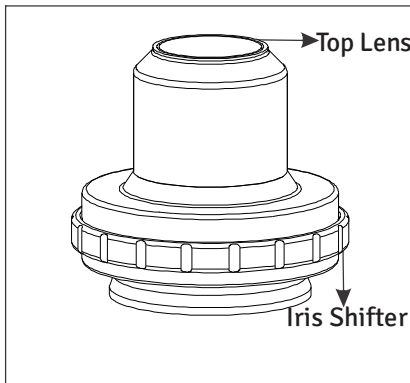

Fig. 9

Lx POL Abbe condenser is has following important basic requirements i.e.

1. Stain free optical system.
2. Rotate knurled ring to open and close IRIS Diaphragm for respective Objective magnification in order to match numerical aperture.

b POLARIZER

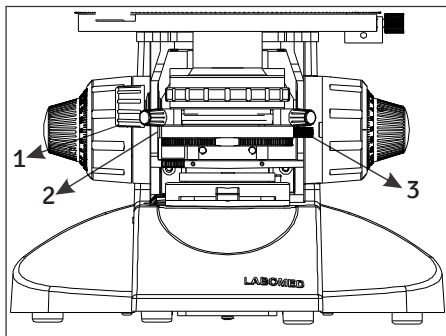

Fig. 10

This high quality primary polarizer (1) is 360 degree rotatable with fiducial marking (2) for quick identification of Polarized/ Cross Polarized positions fig.10

It is ideally located below condenser and with a lockable mechanism (3) fig.10 to stop polarizer filter at desired position for comfortable observation experience.

Lx POL Polarizer is also equipped with a mechanism of swing in/out the polarizer from the light path

c ROUND STAGE

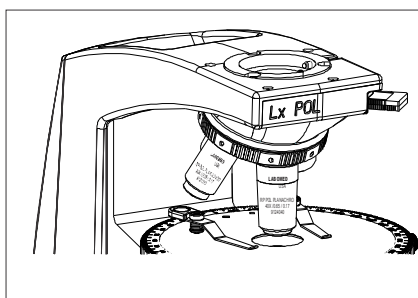

Fig. 11

Lx POL round stage has both the key feature of rotatability & centerability (Fig.11). Lx POL round stage is equipped with the key features of rotatability and centerability (Fig 11). It provides a 360 degree circular rotation which allows the user to study the orientation by coinciding the objective centration with the microscope's optical axis. This makes the center of rotation coincide with the center of field of view. Rotatability allows the user to observe the specimen in the diagonal position (the brightest position of anisotropy).

It is equipped with a vernier scale to measure the accuracy of 0.1 degree and locking provision to stop the stage at desired location. Lx POL round mechanical stage is based on hard steel ball bearing which provides even and smooth jerk free motion across 360 degree.

d CENTERABLE REVOLVING NOSE PIECE

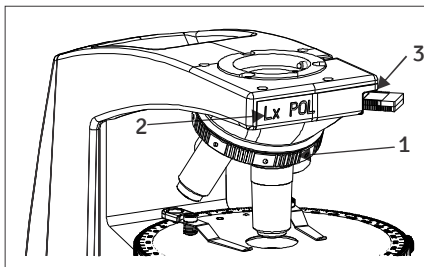

Fig. 12

Lx POL comes with a centerable revolving nose piece to compensate optical axis of each objective as they vary from one assembly to another. Lx POL Nose Piece is fully equipped with centering mechanism for each microscopic optical axis so that the specimen remains in the center when the stage is rotated. Movement of the turret is based on hard steel ball bearing which provides smooth and jerk free motion around 360 degree.

This nose piece is highly precision parfocalized and par centered.

Fig. # 12

1. Objective Centering Allen Screws
2. Nose Piece Cover
3. Port for Lamda Plate

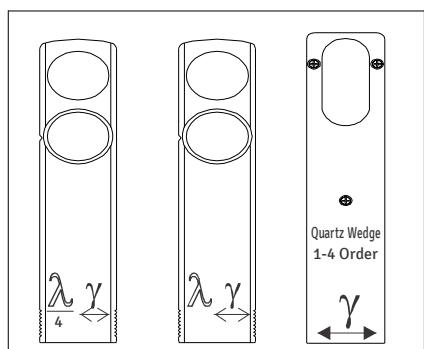

Fig. 12-a

Centerable revolving turret is also equipped with a Nose Piece cover which provides a click stop lockable port for Gypsum Lambda wave plates fig. 12-a. This feature provides comfort while using different Lambda Wave Plates. It is ideally located in between specimen & the Analyzer. It allows to introduce compensator & retardation plates between the cross polarizer which can enhance optical path differences in the specimen details.

e OBJECTIVES

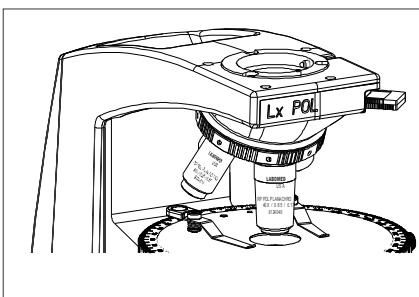

Fig. 13

Lx POL objectives are free from stress & both types of 'strain' i.e. glass characteristics during various stages of the assembly like cementing or mounted in close proximity with tightly fitted frames. Lx POL objectives are assembled only after passing the strict testing. Lx POL comes with standard 4x, 10x, 40x objectives that solve the purposes of viewing specimen in conoscopic & orthoscopes modules. These objectives are anti-refraction coated. Some other objectives like 20x & 100x are also available.

f EYE PIECES

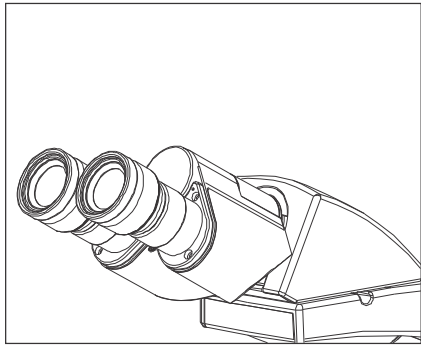

Fig. 14

Lx POL comes with a pair of Eye Pieces. One of the eyepieces has a crosshair reticule to mark the center of the field of view and the second for normal viewing. Orientation of the Eye Piece with respect to the Polarizer and Analyzer is ensured by the eye tube lower that slides into the observation Bino Body tube. These eye pieces also have a focusing mechanism for diopter correction & foldable eye guards to prevent ambient light from entering into your line of vision.

g BERTRAND LENS

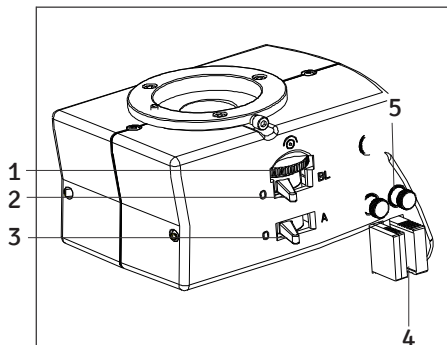

Fig. 15

Lx POL comes with a Bertrand Lens that projects an interference pattern formed at the objective rear focal plane into focus at the microscope image plane. It is capable of examining the objective rear focal plane, to ensure exact adjustment of the illumination aperture diaphragm and to view interference images. These images form in the objective rear focal plane when an optically anisotropic specimen is viewed between cross polarize using a high numerical aperture objective / condenser combination. It is ideally located between analyzer and eye pieces for an easy in and out movement from the light path. Lx POL Bertrand Lens is also centerable with respect to the optical axis of the microscope and has focusable mechanism for a comfortable viewing experience.

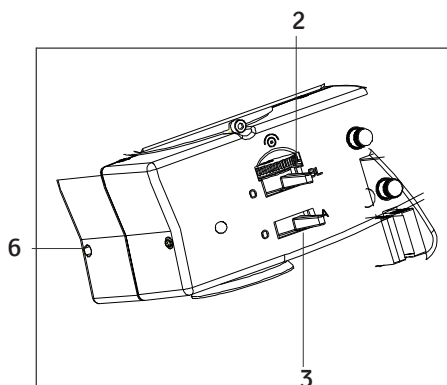

Fig. 16

Fig. # 15 & 16

1. Bertrand Lens Focusing Knob
2. Bertrand Lens Operating Lever
3. Analyzer Operating Lever
4. Gypsum wave Plate
5. Allen Wrench for Objective centering
6. Allen screw for Bertrand Lens Centering.

Fig. 15: Bertrand Lens lever (2) in out “O” position i.e. away from light path.

Analyzer Lever (3) in out “O” position i.e. away from light path.

Fig. 16: Bertrand Lens lever (2) in “BL” position i.e. in light path.

Analyzer Lever (3) in “A” position i.e. in light path.

a OBSERVATION HEAD

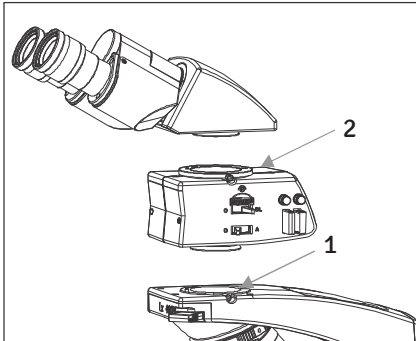

Fig.17

Install the observation head using the following procedure:

Refer Fig. 17

1. Using allen wrench 3mm (provided), loosen the Head Locking Screw (1) and remove the dust cover cap provided in dovetail cavity as well as on observation head dovetail.
2. Mount the Analyzer by engaging the dovetail provided on the attachment into the dovetail cavity on the microscope arm and tighten the Head Locking Screw (1) see figure 17.
3. Remove the Dust Cover Cap from Observation Head Dovetail and mount the Observation Head by engaging the dovetail provided at the bottom of the head into the dovetail cavity on on the analyzer attachment.
4. Tighten the Head Locking Screw (2) after positioning the Observation head as desired. See figure 17.

b EYEPIECES

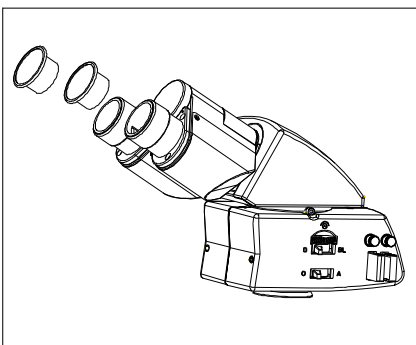

Fig.18

Insert the eyepieces into the ocular tube of Observation Head using following procedure:

1. Remove the protective caps from the observation tube.(Fig. 18)
2. Insert eyepieces into the ocular sleeve for use (Fig. 19).

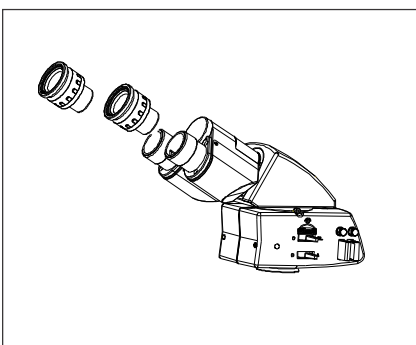

Fig.19

c MOUNTING THE DAYLIGHT (BLUE) FILTER

Fig. 20

This filter modifies the color of observation light into a natural (daylight) color.

Place Blue filter on Koehler Mount.

d STAGE CLIPS

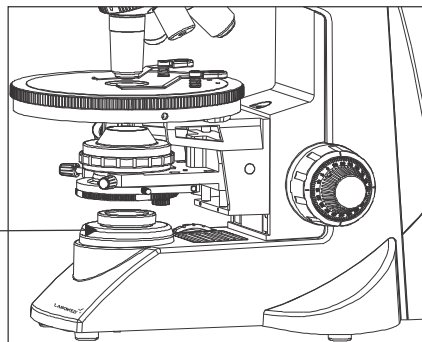
Fig. 21

Fix Stage Clips on round rotatable stage for holding the POL specimen.

e CONNECTING POWER CORD

Fig. 22

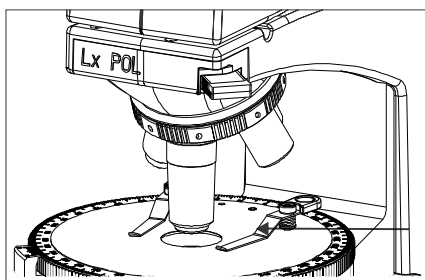
Attach the Power cord and plug it into a grounded electrical outlet.

1. Flip the main switch to "I" (ON) as shown in Figure 22.
2. Rotating the light intensity adjustment knob in the direction of the arrow increases brightness and rotating knob in the opposite direction decreases brightness. The intensity bar next to the knob indicates the direction of the intensity level.

Note: Never use an adapter between the power cord and the power source; it will render the microscope grounding feature ineffective.

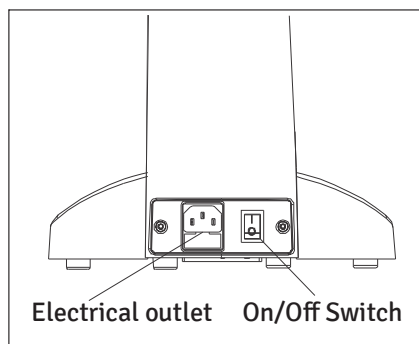
a PREPARATION FOR CENTRATION

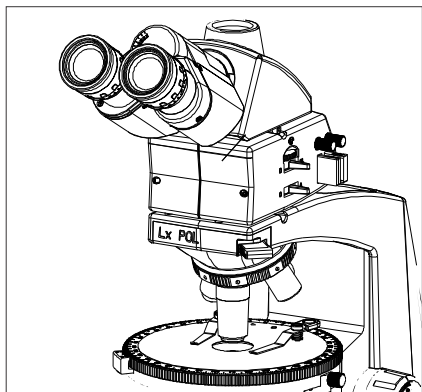

Fig. 23

Step: 1

Disengage the Analyzer and Bertrand Lens by switching the operating lever to “O” position as shown in Fig. 23. Fully open the aperture diaphragm of the condenser by rotating its ring to the extreme left.

Lower the microscope stage. Place a POL specimen on the stage. Swing in the 10x objective into working position. Raise the Microscope stage using the coarse adjustment knob until you reach its positive stop. Use the fine adjustment knob to bring the POL specimen into focus by lowering down the stage.

b KOEHLER ILLUMINATION CENTRATION

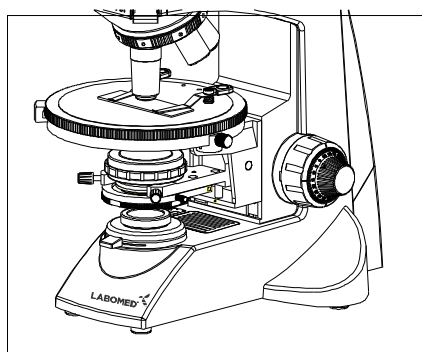
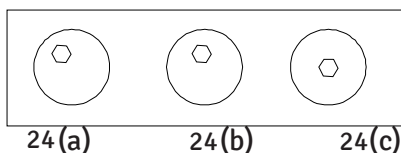

Fig. 24

Step: 2

Swing in the 10x objective into working position. Flip in top lens of condenser in light path. Close the Koehler field diaphragm so that its closed isirs leaves image is present within the field of view. Use the condenser focusing knob to bring the image into sharp focus. Operate the condenser centering screws simultaneously to Center the image of the field diaphragm Ref. Fig 24 (a), (b), (c). After centration open the field diaphragm until the Image (iris leaves) disappears just beyond the field of view.



c ABBE CONDENSER CENTRATION

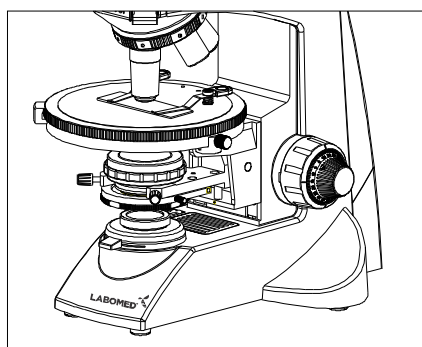

Fig. 25

Step:3

Look through 10x Objective & Eye Pieces cross hair scale. Close the condenser diaphragm until approximately 20-25% of the iris leaves fill the field of view. Adjust the centering of the diaphragm by maintaining condenser centering screws simultaneously with reference to Eye Piece cross hair scale Ref. Fig.25 (a).

Note: When changing the objective, adjust the condenser field diaphragm with respect to each objective.

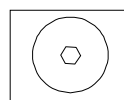

Fig. 25 (a)

d OBJECTIVE CENTRATION

Fig. 26

Swing in 10x objective in the light path. Adjust the condenser aperture diaphragm. Retrieve the two centering keys (Ref Fig 15 Part 5) and insert them in the centering holes (Ref Fig 12 Part 1) above the objective you want to center. Focus the POL sample.

- i) Bring some prominent point of the specimen to the center of the Eye Piece crossline (Fig 26 (a)).
- ii) Loosen the stage locking thumb screw which will allow the Round Stage to rotate 360 degree horizontally. Rotate the round stage 360 degree until the prominent point of the specimen is furthest away from the center of the Eye Piece crossline, it may even be outside the field of view. (Fig 26 (b)).
- iii) Adjust the image with the centering screws over the objective until the prominent point of the specimen is midway between the center of the Eye Piece crossline. (Fig 26 (c)).
- iv) Adjust the specimen so that the prominent point is at the center of the Eye Piece crossline. (Fig 26 (d)) Check that it stays at the center of the Eye Piece crossline when the stage is rotated 360 degree. Repeat the centering process if necessary.

Note: Each objective must be centered separately.

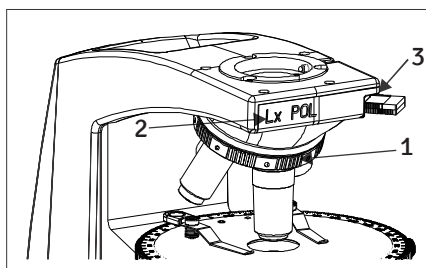
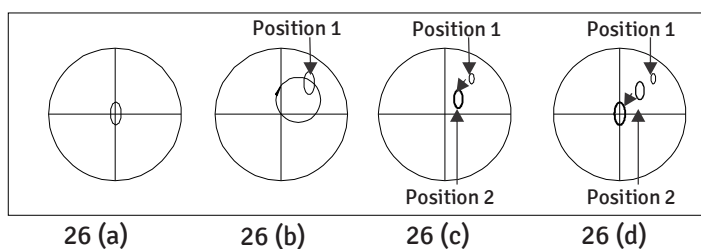

e EXTINCTION ADJUSTMENT

Fig. 27

1. Remove all compensator; specimen & test plates out of light path.
2. Swing in 10x Objective in the light path.
3. Bring preset vibration direction Analyzer plate by moving Analyzer lever to 'A' position (Ref. Fig 17 Part-3)
4. Bring polarizer to light Path (Ref. Fig 27) loosen polarize lock screw for free 360 degree rotation of polarizer.
5. Rotate polarizer until you achieve complete extinction. Lock Polarizer by tightening Polarizer locking screw.

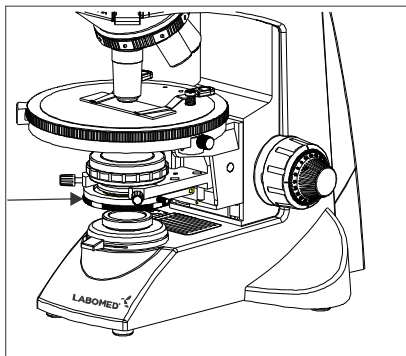
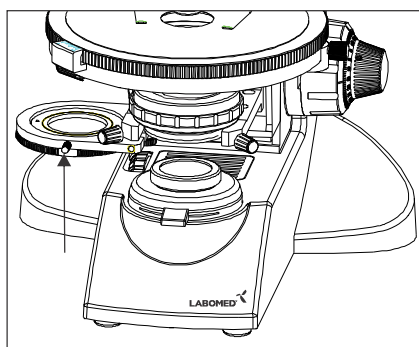

Polarizer away from Light Path

Fig. 27-a

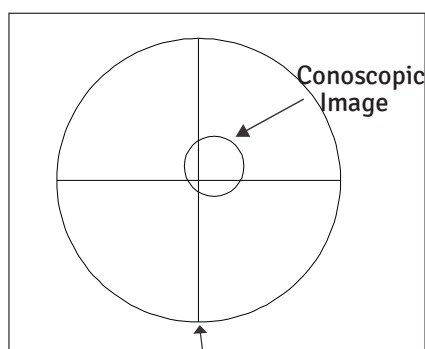
f CONOSCICAL OBSERVATION

Cross Lines

Fig. 28

1. Bring an objective of your choice between 20x to 100x in the light path. Bring the Pol specimen into focus.
2. Keep the Abbe condenser in its lowest position.
3. Open the aperture diaphragm.
4. Swing in lever of Bertrand lens to 'BL' Ref. Fig 17 Part (2) and focus image by rotating Bertrand Lens focusing knob Ref. Fig 16 Part (1).

Note: If the conoscopic image is dark, then move the condenser upward to find the suitable position where the image is brightest.

Conoscopic image may not be at the centre of eye piece cross line intersection. However it will have no measurable effect due to universal infinity optical design.

14 SUMMARY OF POLARIZED LIGHT OBSERVATION PROCEDURE

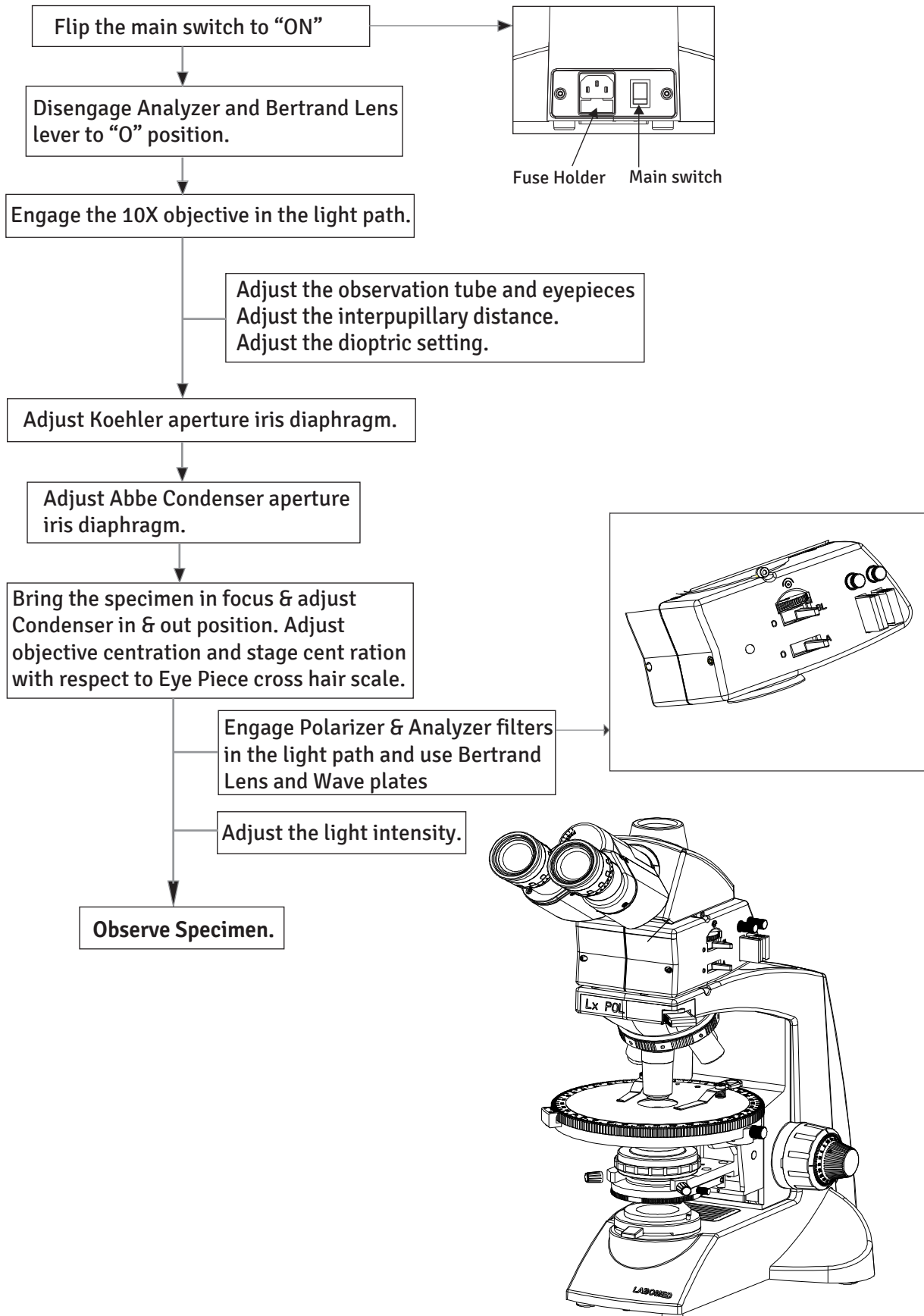

a PLACING SPECIMEN ON THE STAGE

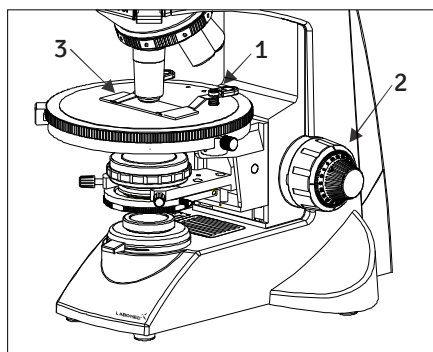

Fig. 29

1. Rotate the coarse adjustment knob (2) in anticlockwise direction to fully lower the stage.
2. Press the spring loaded clip lever (3) by pushing lever handle (1), place the specimen by sliding the specimen glass plate (s) on the stage.
3. After positioning your specimen slides, (1max) release the lever handle.
4. Rotating the stage 360° to achieve best viewing position. The degree of position can be noted.

Cover glass

This is the glass plate paced on the specimen. For optimum optical performance, the cover glass thickness, which is the distance from its surface to the specimen surface, should be 0.17mm.

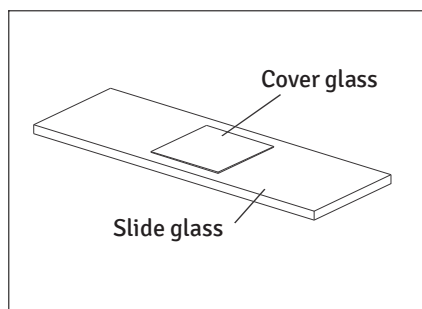

Fig. 30

Slide glass

This glass plate should ideally have a length of 76mm, width of 26mm ± 1mm and thickness between 0.9 and 1.4mm.

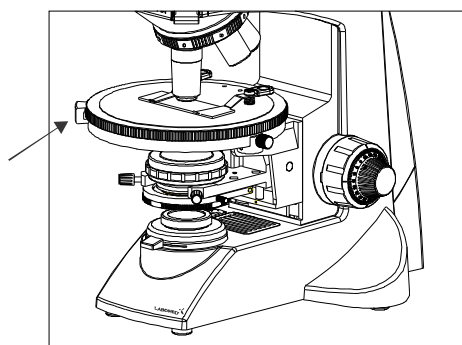

Fig. 31

“Vernier Scales”

These scales allow for easy identification of the specimen’s position (coordinates), making it easy to return to a particular region of interest after scanning the slide. (Figure 31)

b ADJUSTING THE FOCUS

Fig. 32

Focusing Procedure (Figure 32)

1. Rotate the coarse adjustment knob (1) clockwise so that the objective (3) is as close as possible to the specimen (we recommend starting with 10X).
2. While observing the specimen through the eyepieces, slowly rotate the coarse adjustment knob (1) counterclockwise to lower the stage.
3. When coarse focusing of the specimen is obtained (an image is observed), rotate the fine adjustment knob (2) for fine detail focusing.

Working Distance (WD)

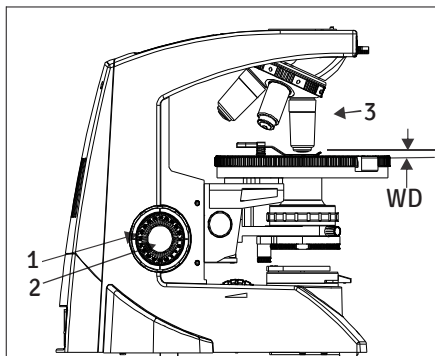
The WD refers to the distance between each objective and the specimen, when acute focus of the specimen is obtained.

OBJECTIVES					EYE PIECE 10x/20 W.F. (4140010)			ABBE CONDENSER	
Objective Magnification	N.A.	W.D. (mm)	Cover Glass	Resolution (μm)	Total mag.	Field of view/mm	Depth of focus(μm)	Obj. N.A.	Flip Position (In / Out)
2.5x (9124002)	0.08	20.0	0.17	5.0	25x	8.0	400	0.08	Out
4x (9124005)	0.10	30.0	0.17	3.36	40x	5.0	200	0.10	Out
10x (9124010)	0.25	4.04	0.17	1.34	100x	2.0	30	0.25	Out
20x (9124010)	0.45	1.10	0.17	0.75	200x	1.0	6	0.45	In
40x (9124010)	0.65	0.45	0.17	0.52	400x	0.50	3	0.65	In
100x(oil)(9124010)	1.25	0.14	0.17	0.27	1000x	0.20	0.70	1.25	In

c ADJUSTING THE INTERPUPILLARY DISTANCE (IPD)

Fig. 33

The inter-pupillary distance adjustment consists of regulating the two eyepieces to align with both eyes' pupils so that you can observe a single microscope image through two eyepieces in stereo vision. This greatly helps to reduce fatigue and discomfort during observation.

While looking through the eyepieces, move both eye tubes laterally until the left and right fields of view coincide completely. The position of index dot (•) indicated the inter-pupillary distance value.

Note your interpupillary distance so that it can be quickly referred to in the future. This is happen when multiple users work with the microscope.

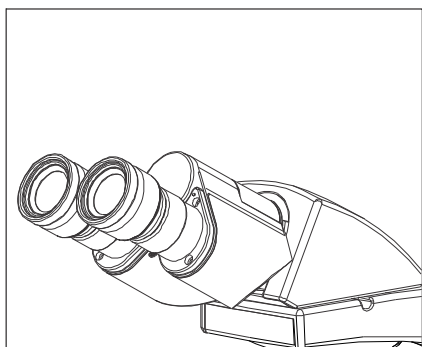
d ADJUSTING THE DIOPTER

Fig. 34

Procedure for adjusting the diopter:

1. Rotate the right eyepiece to match the marking of your IPD (If your IPD is 64, rotate the eyepiece to 64 mark).
2. While looking through the right eyepiece with your right eye, rotate the coarse and fine adjustment knobs to bring the specimen into focus.
3. While looking through the left eyepiece with your left eye, rotate only diopter adjustment ring on the eyepiece until specimen is at its best possible focus.

Using the Eye Guards**When Wearing Eyeglasses**

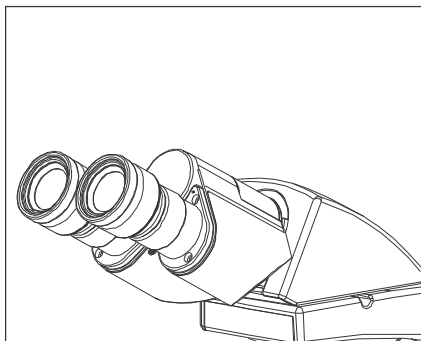
Use with the eye guards in the normal, folded-down position. This will prevent the eyeglasses from being scratched.

When Not Wearing Eyeglasses

Extend the folded eye guards outwards (direction of the arrow) to prevent ambient light entering into your line of vision.

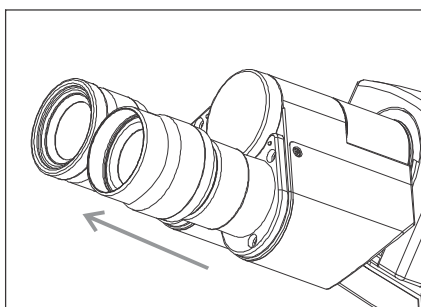

Fig. 35

e ADJUSTING THE CONDENSER POSITION AND APERTURE IRIS DIAPHRAGM

Fig. 36

The condenser is most often used in the highest position. If the observed field of view is not bright enough, brightness may be improved by lowering the condenser slightly.

1. Rotate the condenser height adjustment knob (2) to move the condenser to the highest or desired position .
2. The aperture iris diaphragm ring (1) has an objective magnification scale. Slide the diaphragm lever left right to achieve the desired illumination level.

f SWITCHING THE OBJECTIVES

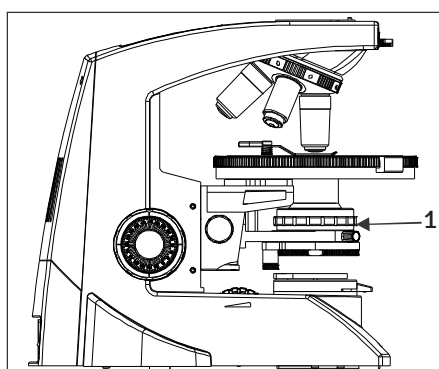
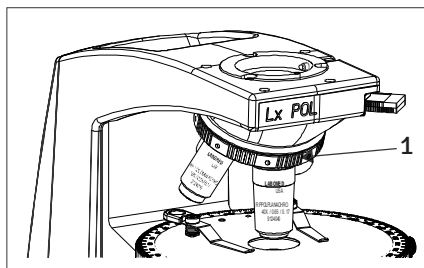

Fig. 37

Rotate the revolving nosepiece (1) so that the objective to be used is in line above the specimen. Always use the knurled surface to rotate the objective nose piece.

g USING THE 100X IMMERSION OBJECTIVE

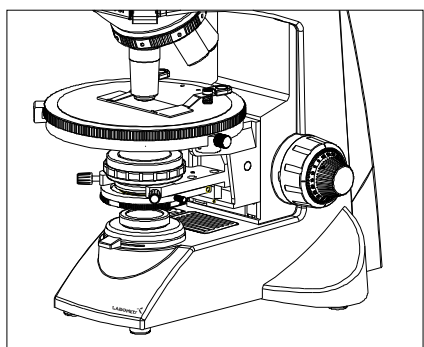

Fig. 38

The designated immersion oil should be in contact with the cover lens of the 100X immersion objective. If not, the specimen will appear distorted and dull. It is recommended that LABOMED immersion oil is always used.

Immersion Process:

1. Bring the specimen in focus using first the 10x, then 40x objective.
2. Disengage the 40x cycling towards 100x, and place a drop of immersion oil on the center point of the specimen.
3. Rotate the revolving nose piece to engage the immersion objective and rotate the fine adjustment knob to bring the specimen into focus
(Since air bubbles in the oil will affect the image quality, make sure that the oil is free of bubbles. To remove bubbles, rotate the revolving nosepiece slightly to agitate the oil).
4. The condenser of this microscope manifests the full performance when oil is placed between the slide glass and the front lens of condenser. If oil is not placed there, the observed image may appear dark.
5. After use, remove oil from the objective front lens by wiping with lens tissue slightly moistened with an ether (70%) alcohol (30%) mixture.



Caution:

If immersion oil makes contact with your eyes, rinse eyes out thoroughly with fresh water. If immersion oil makes contact with skin, wash affected areas with soap and water. If prolonged discomfort is experienced, consult your physician immediately.

Under certain conditions, performance of the unit may be adversely affected by factors other than defects. If problems occur, please review the following list and take corrective action as needed. If problem persists, please contact LABOMED or your local LABOMED dealer.

OBSERVATION	CAUSE	REMEDY
1. Uneven brightness in observation field	The objective is not engaged in the light path	Engage the objective into position until the nose turret clicks
	The condenser is too low	Raise up to achieve more light
	The objective, eyepieces, condenser and/or window lens are dirty	Clean them thoroughly as previously Prescribed in "Optical Cleaning"
2. Dust or stains are visible in observation field	The eyepieces, condenser, window lens and/or specimen glass is dirty	Clean glass parts thoroughly with lens tissue and cleaning solution Prescribed in "Optical Cleaning"
3. Glare visible in field of view	The condenser is too low	Raise condenser light
	The condenser iris diaphragm ring is closed	Adjust the aperture according to the objective magnification
4. Observation image is hazy or unclear	The objective is not engaged in the light path	Engage the objective into position until it clicks
	The objective, eyepieces, condenser and/or specimen glass is dirty	Clean glass parts thoroughly with lens tissue and cleaning cloth
	Immersion oil is not used with an immersion objective	Use immersion oil as suggested
	Bubbles are present in immersion oil	Remove the bubbles by agitation
	The specified immersion oil is not used	Use the immersion oil supplied by LABOMED
5. Part of image is defocused	The objective is not engaged in the light path	Engage the objective into position until the nose turret clicks
	The specimen is not set properly on the stage	Set the specimen correctly on the stage and secure using the specimen holder
6. Coarse focus adjustment cannot lower the stage low enough	The condenser is too low	Raise the condenser
7. Fields of view through both eyepieces is inconsistent	The interpupillary distance is not adjusted properly	Adjust IPD to the appropriate setting
	Dioptric compensation for the two eyes is not set	Adjust diopter settings
	The left and right eyepieces are of different magnification	Ensure that both eyepieces are of same magnification. LABOMED does not recommend using third party eyepieces in conjunction with LABOMED eyepieces

OBSERVATION	CAUSE	REMEDY
8. Objective hits the specimen when an objective is switched to a higher magnification objective	The specimen slide is upside down	Set the specimen correctly with the cover glass facing upwards
	The cover glass is too thick	Use a cover glass with thickness of 0.17mm
	The stage is raised too high	Lower the stage
	The slide has slipped from the slide holder	Re-position the slide in the slide holder
	Slide is of excessive thickness	Use slides with thickness between 0.9 and 1.4mm
9. Bulb does not turn On	Bulb is not mounted	Attach a bulb
	Bulb is blown	Replace the bulb
	The power cord is unplugged/ Not firmly secured	Ensure power cord is securely plugged into the box socket + wall outlet
	Fuse is blown	Check and replace with live fuse
10. Bulb blows easily	The specified bulb is not used	Replace with the specified bulb
11. Field remain dark even Bulb is on	In the Exintetion Position	Remove Analyzer from light path by switch Analyzer lever to out "O" position. Swing out Polarizer from light path.
	Bertrand Lens in the Light Path (BL).	Swing out Bertrand Lens to out "O" position i.e. away from light path.
12. Conoscopic image is not visible	Bertrand Lens is away from Light Path.	Bring Bertrand Lens in light path at "BL" position.
	Condenser Top Lens not in the Light Path.	Swing in Top Lens of condenser in the Light Path.
	Using lower magnification objective.	Go to specified magnification objective i.e. from 20x to 100x.
13. Extinction failure	Analyzer & Polarizer out of the light path.	Bring Analyzer & Polarizer of the light path.
	Analyzer & Polarizer are not in cross positions.	Adjust Polarizer by rotating to get complete extinction.

1. Illumination	Built-in illumination system Halogen/ LED		
2. Focusing mechanism	Stage height adjustment mechanism Fine adjustment scale: 3.0μm per graduation Fine adjustment stroke: 0.3mm per turn Total stroke: 12.7mm Co-axial coarse and fine focusing on ball drive		
3. Revolving nose piece	Quadruple positions fixed (Reverse angle)		
4. Observation tube		Binocular	Trinocular
	Field number	20 (Standard)	20 (Standard)
	Tube tilting angle	30°	30°
	Interpupillary distance adjustment range	48-75	48-75
5. Stage	Size	Dia 160mm	
	Rotatability	360 degree	
	Specimen holder	Spring Loaded stage clips	
6. Condenser	Type	Abbe condenser (daylight filter detachable)	
	N.A.	1.25	
	Aperture iris diaphragm	Built-in	
7. Dimensions & Weight	405mm (L) x 210mm (W) x 425mm (H); 7 kg net		
8. Electrical	Halogen	6V-20W	
	Life time	upto 2,000 Hours	
	LED Battery	7.4V.1000mA	
	Charging time	upto 5 hours (with totally consumed battery)	
	Total battery time	upto 2 hours after fully charging	
9. Operating environment	Indoor use Altitude: Max. 2000 meters Ambient temperature: 5° to 40°C (41° to 104° F) Maximum relative humidity: 80% for temperature up to 31°C (88°F), Decreasing linearly through 70% at 34°C (93°F), to 50% relative humidity at 40°C (104°F) Supply voltage fluctuations: Not to exceed ±10% of the normal voltage. Pollution degree: 2 (in accordance with IEC60664) Installation/Over voltage category: II (in accordance with IEC60664)		

Revision History

Rev. No.	Date of Release	ECR #	Change	App. By
1.4	July 23,2021	DCR/06/21	Added LED Information Index & Pages Reset	S.Bal



Labo America Inc.
920 Auburn Court
Fremont, CA
94538
U.S.A.

Phone: 510-445-1257
Fax: 510-991-9862
Email: sales@laboamerica.com
www.laboamerica.com

EU|REP.

Labomed Europe
Essebaan 50
NL-2908 LK Capelle a/d IJssel
The Netherlands
Tel: +31 (0)10 4584222
Fax: +31 (0)10 4508251
E-mail: info@labomedeuropa.com

