

# CxL Phase Contrast Kit User Manual

To ensure proper use of this instrument as well as to avoid injury while operating instrument, understanding this manual completely before use is highly recommended.

9136000-795

**[www.laboamerica.com](http://www.laboamerica.com)**

Issue 1.3  
Printed on July, 2023

# INTRODUCTION

Phase contrast is the method used in light microscopy and was developed on the principle that if you speed up a direct light path, you can cause destructive interference patterns in a viewed image. These patterns make details in the image appear darker against a light background. To cause these interference patterns, a system of rings located both in the objective lens and in the condenser system must overlap. When aligned correctly, light waves emitted from a light source reach your cornea one-half of the wavelength out of phase, resulting in a specimen with details that are greatly enhanced. Phase contrasting is only useful on the specimen that is colorless as well as transparent in nature and usually difficult to distinguish from its surroundings. Such specimens are referred to as "Phase objects". Examples of phase objects include cell parts in protozoans, bacteria sperm tails and other types of unstained cells.

## PACKING LIST

### CxL Phase Contrast Kit (9136000)

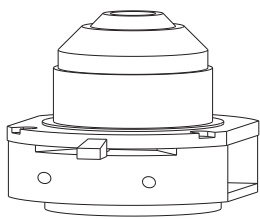

1

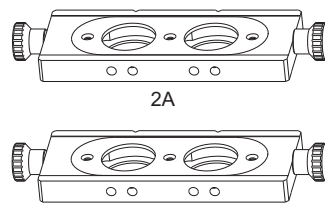

2A  
2B

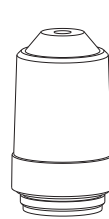

3

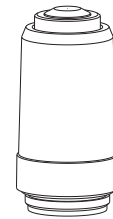

4

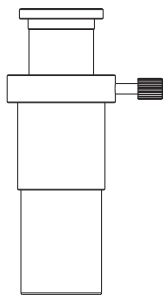

5

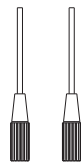

6

- 1) Abbe Condenser (3124041)
- 2A) 40X Phase Annulus Slider (9136045)
- 2B) 10X Phase Annulus Slider (9136040)
- 3) Phase Contrast 10X (9132010) and 40X (9132040) Objectives
- 4) Green Filter (3126065)
- 5) Centering Telescopic Eyepiece (3126005)
- 6) Allen Keys

*Please make sure all contents of the Phase Contrast Kit are intact. If any physical damage is visible, please contact your local distributor.*

# INSTALLATION

1. Loosen the thumb screw (1) to remove the condenser. Replace the condenser with the new Abbe condenser provided in the phase kit.
2. Keep printed face of slider towards you and two index slots on rear side such that printing is straight readable. Remove left hand thumbscrews of phase slider and insert gently into slider slot provided in Abbe condenser right end. Such that when 10x phase is legible outside phase ring is in the field of view
3. To ready phase slider for the use, gently push it into slider aperture provided in the Abbe condenser as shown in Fig.1 with all legible text and part number facing you. If inserted upside down or the wrong side facing you, phase rings may be out of line causing distortion in image. Once in place, re-tighten both thumbscrews to secure slider.
4. Remove standard objectives from objective turret and fix 10X and 40X phase objectives in place. Objectives other than phase contrast objectives do not contain phase rings, and therefore will not produce a phase object.
5. Remove blue filter from its seat on the collector lens and replace it with the green filter provided with the phase kit.

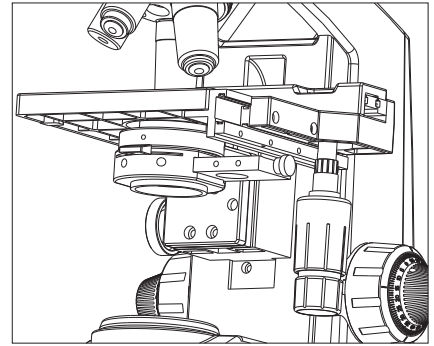

Fig. 1

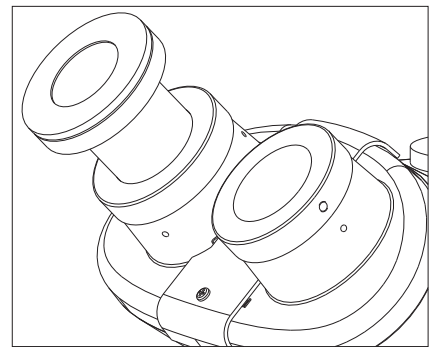

Fig. 2

## SET UP FOR PHASE CONTRAST MICROSCOPY

1. Turn microscope On and close the diaphragm of the Abbe condenser to minimum position by shifting the condenser lever to control the amount of collected light hitting condenser lens.
2. Next engage the bright field ring by pushing the slider all the way in and open the condenser diaphragm to a comfortable level of light by adjusting condenser level. Place any specimen slide on stage and focus the specimen with the 10X phase objective. Remove one eyepiece and insert the centering telescopic eyepiece in its place as shown in Fig.2.
3. Loosen the thumbscrew of the telescopic eyepiece. While looking into the telescopic eyepiece, extend the front lens until the dark ring of 10X objective in the field of view becomes as sharp as possible (more detail is given on next page). Tighten the telescopic eyepiece's thumbscrew and image will remain in focus (Fig 3).
4. Pull the phase slider out one click stop to bring the 10X ring into position (you should be able to read 10X on the front of the slider).
5. Two holes are provided on the front side of Abbe condenser for centering the phase annulus by use of the two allen keys provided as shown in Fig 4.

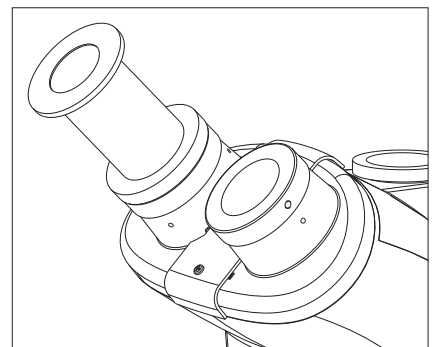

Fig. 3

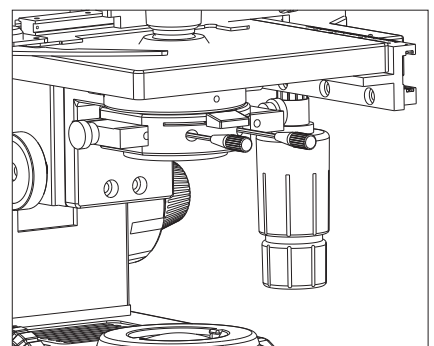
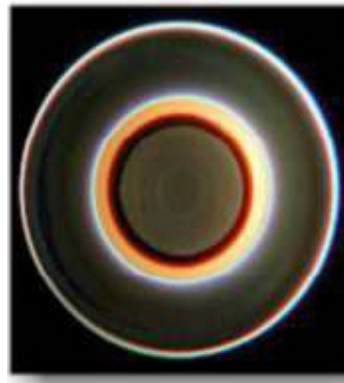

Fig. 4

## CALIBRATING THE INSTRUMENT

6. While looking through the telescopic eye piece, two rings will be visible-one dark and the other bright. These rings will most probably be out of alignment. Using the two allen keys provided as shown in Fig. 6, align the rings so that they overlap with each other as shown below.



7. Remove the centering telescopic eye piece and place the original eye piece in the eye tube. Place a specimen slide of choice on stage. The microscope is now ready for phase contrast observation.
8. Repeat the entire process when observing through 40X phase with the appropriate 40X phase annulus slider. At neutral position of phase slider (slider pushed all the way in), the microscope can be used in simple bright field mode.

## CARE AND MAINTENANCE

- Loose particles can be removed from the surface of the condenser, diaphragm, or phase annulus by gently wiping them with lens tissue dampened with Acetone or Methanol.
- It is better to avoid leaving finger prints on the surface of condenser, phase annulus.
- When not in use for long time, it is recommended to store the phase contrast kit in its original packaging.

Our policy is one of continuous development. Labo America, Inc., reserves the right to change design and specifications without prior notice.

**Labo America Inc.**  
920 Auburn Court  
Fremont  
CA 94538

U.S.A.  
Telephone: 510 445 1257  
Fax: 510 991 9862  
sales@laboamerica.com

